

DIGITAL INDUSTRIES SOFTWARE

# Simcenter SCADAS Mobile and Lab Eight-channel, Extended Range Input Module for Voltage, ICP<sup>®</sup> and Charge

Simcenter/VC8-ER/2406/20240625

## Product Information Sheet

### Summary

#### VC8-ER input module

The VC8-ER supports eight channel signal conditioning and signal processing for voltage sources and ICP or piezoelectric sensors in a single Simcenter SCADAS Mobile or Simcenter SCADAS Lab slot.

The VC8-ER offers the unique combination of ultra-low power consumption, 204.8 kHz 24-bits analogue to digital conversion, and a spurious free dynamic range of 150 dB.

## SUPPORTED TRANSDUCERS



## TYPICAL APPLICATIONS



## BENEFITS

- 8 input channels via microdot connectors
- Channel selectable Voltage, ICP and Charge modes
- Extended charge input ranges to support special charge accelerometers

## FEATURES

- Smart sensor support
- Analog anti-alias filter
- Analog and digital overload detection with LED indication on front-panel
- ICP cable check with LED indication
- 150 dB dynamic range eliminates the need for range setting
- Built-in calibration for improved specifications over a longer period

### Signal conditioning

Each input channel has a voltage amplifier input with ICP supply and a charge amplifier input for direct interfacing to ICP and piezoelectric sensors.

The overload LED indicates both analogue overloads, detected at the input amplifier, and digital overloads, detected by the digital signal processor. The VC8-ER has an ICP cable check circuit to detect an open loop or short circuit in the sensor cable; errors are indicated through a front-panel LED for optimum user feedback and simultaneously transferred to the host as well.

VC8-ER supports smart sensors according to IEEE 1451.4 to read the Transducer Electronic Data Sheet (TEDS) with essential information including sensor type, sensitivity, calibration date, coordinates etc.

The ultra-low-noise charge input supports full-scale ranges from 3160pC to 100,000pC full scale. A digital high-pass filter can be switched on to eliminate pyroelectric noise.

### Analog to digital conversion

The VC8-ER uses low-power high performance 204.8 kHz 24-bit sigma-delta analogue to digital converters.

A 4-pole analogue anti-alias filter precedes each ADC. A wide range of digital decimation filters reduces the bandwidth in steps of 2 and 2.5.

### Specifications VC8-ER

#### Input function

Single ended voltage, ICP or charge input via grounded microdot socket

General information		VC8-er specifications
Product name	SCL-VC8-ER, SCM-VC8E-ER	
Description	Simcenter SCADAS Mobile and Lab Eight-channel Extended Range Input Module for Voltage, ICP® and Charge	
Input ranges differential input	-	
Input ranges charge input	±3,160 pC, ±10,000pC, ±31,600pC, ±100,000 pC	
Input ranges V/ICP input	±316 mV, ±1 V, 3.16 V, ±10 V	
Transducer connector	Eight (8) Microdot connector for sensor input	
Supported transducers		
	Single ended AC, DC sensors	
	Voltage and ICP sensors	
	Piezoelectric charge sensors	
A/D Converter		
Max. sampling rate	204.8 kHz, can be downsampled in steps of 2 and 2.5	
Max. bandwidth (filter off, -3 dB)	Bandwidth 92 kHz for all input ranges except: At ±100,000 pC input range, the full-power bandwidth is limited to 20 kHz. At ±31,600 pC input range, the full-power bandwidth is limited to 60 kHz.	
ADC Architecture	24-bit Sigma Delta ADC	
Coupling	DC, AC, ICP, charge in single ended mode	
Filter		
High Pass Filter	Software selectable high pass filter with 0.5 Hz, 7 Hz, 25 Hz and 60 Hz cut off frequencies.	
AC Coupling	Charge Mode: 0.48 Hz ± 6 % Voltage Mode: 0.48 Hz ± 3 %, 7 Hz ± 2 %	
Decimation filter	Reduces bandwidth prior to signal processing; bandwidth can be down-sampled in steps of 2 and 2.5.	
Analog anti-alias filter	4-pole Equal Time Delay filter with 164 kHz cut-off frequency and 0.01 dB flatness, 150 dB/oct digital filter with 100 dB alias protection provides an alias free bandwidth of 92 kHz	
Transducer identification		
TEDS	TEDS class 1 (ICP sensors) supported according to IEEE 1451.4 Maximum TEDS cable length is 80 m	
Power		
Power consumption/power budget	During normal operation, no overload and ICP supply switched on: 5.25 W	

Power feedback	<p>LED on the module front panel, providing information on connection, power status and any sensor supply overload/underload. During system booting and startup, the LED on channel 1 will be used to indicate module status (active) using a different LED color and/or blinking pattern.</p> <table border="1"> <thead> <tr> <th>LED Modes</th> <th>Alarm</th> </tr> </thead> <tbody> <tr> <td>ICP: Green</td> <td>Overload: Red</td> </tr> <tr> <td>Charge: Blue</td> <td>ICP error: Yellow/Red blinking</td> </tr> <tr> <td>TEDS reading: Yellow blinking</td> <td>TEDS listen mode: Green or Blue blinking</td> </tr> </tbody> </table>		LED Modes	Alarm	ICP: Green	Overload: Red	Charge: Blue	ICP error: Yellow/Red blinking	TEDS reading: Yellow blinking	TEDS listen mode: Green or Blue blinking
LED Modes	Alarm									
ICP: Green	Overload: Red									
Charge: Blue	ICP error: Yellow/Red blinking									
TEDS reading: Yellow blinking	TEDS listen mode: Green or Blue blinking									
ICP sensor supply	3.5 mA±15 % from 28 V isolated source, over the LMS SCADAS Mobile operating temperature range.									
<b>Input impedance</b>										
ICP mode (AC)	1 MΩ ±1%    260 pF									
<b>Slew rate</b>										
V/ICP (single ended)	20V/μs									
Charge input	20V/μs									
<b>Signal to noise ratio (SNR)</b>	<b>Charge input (typical)</b>	<b>Single ended input (typical)</b>								
±10 V		107 dB								
±3.16 V	-	107 dB								
±1 V		106 dB								
±0.316 V		101 dB								
±100,000 pC	104 dB									
±31,600pC	106 dB									
±10,000pC	103 dB	-								
±3,160 pC	95 dB									
Measured between 10Hz to 20KHz, with 32k block size, 16 averages										
<b>Spurious Free Dynamic Range (SFDR)</b>	<b>Charge input (typical)</b>	<b>Single ended input (typical)</b>								
±10 V		150 dB								
±3.16 V	-									
±1 V		148 dB								
±0.316 V		140 dB								
±100,000 pC	150 dB									
±31,600pC		-								

Product Information Sheet

	±10,000pC	148 dB	
	±3,160 pC	140 dB	
Measured between 100Hz to 20KHz, with 32k block size, 16 averages			
Crosstalk		Charge input (typical)	Single ended input (typical)
	±10 V		108 dB
	±3.16 V		117 dB
	±1 V	-	120 dB
	±0.316 V		120 dB
	±100,000 pC	94 dB	
	±31,600pC	100 dB	
	±10,000pC	107 dB	-
	±3,160 pC	111 dB	
Tested at 1.5kHz frequency			
Total Harmonic Distortion (THD)		Charge input (typical)	Single ended input (typical)
	±10 V		
	±3.16 V		98 dB
	±1 V	-	
	±0.316 V		91 dB
	±100,000 pC		
	±31,600pC	98 dB	
	±10,000pC		-
	±3,160 pC	91 dB	
At 1 kHz frequency, 25.6 kHz bandwidth, measured with a block size of 6400 Hz			
Amplitude accuracy			
		Voltage input: At 1 kHz better than +/- 0.1% at 23 °C	
		Charge input: At 1 kHz better than +/- 1.2% at 23 °C	
Gain drift			
		+/- 0.1% between 5 to 40 °C	
Residual offset			
		Better than +/- 0.1% at 22°C ± 2°C	
Offset drift		Charge input (typical)	Single ended input (typical)
	±10 V	-	< ± 0.1 % between 5 °C and 40 °C

Product Information Sheet

	±3.16 V		
	±1 V		
	±0.316 V		
	±100,000 pC		
	±31,600pC	< ± 0.1 % between 5 °C and 40 °C	-
	±10,000pC		
	±3,160 pC		
<b>Phase match between any two channels (at 9.9 kHz)</b>			
		<b>Charge input (typical)</b>	<b>Single ended input (typical)</b>
	±10 V		
	±3.16 V	-	0.3°
	±1 V		
	±0.316 V		
	±100,000 pC		
	±31,600pC	0.3°	-
	±10,000pC		
	±3,160 pC		
<b>Protection</b>			
	Input protection	28Vrms continuously without damage, charge input up to: ±500,000 pC	
	Sensor check	ICP sensor check for open loop and short circuit detection. ICP cable check checking the sensor bias voltage continuously for open loop and short circuit with indication by LED in the front panel.	
	ESD protection	According to EN61000-4-2, level 2 and ISO10605	
	EMC protection	Comply with CE-EMC directive, when installed in a SCADAS Mobile frame	
	Overload detection and indication	Analog overload detection at the input is combined with digital overload detection after the ADC; overloads are indicated on the front panel LED and transmitted to the host.	
	Shock protection	MIL-STD-810G specified in MIL-STD-810G method 516.5, Shock Amplitude: 60 gpk.	
	Vibration protection	MIL-STD-810G method 514.5, procedure 1, Category 24: RMS 7.694 g	
	Ambient operating temperature range	-20 °C to +55 °C	
	Storage temperature range	-20 °C to +70 °C	
<b>Housing</b>			
	Dimensions	One SCADAS slot (Microdot)	
<b>Connector and pinning layout</b>			

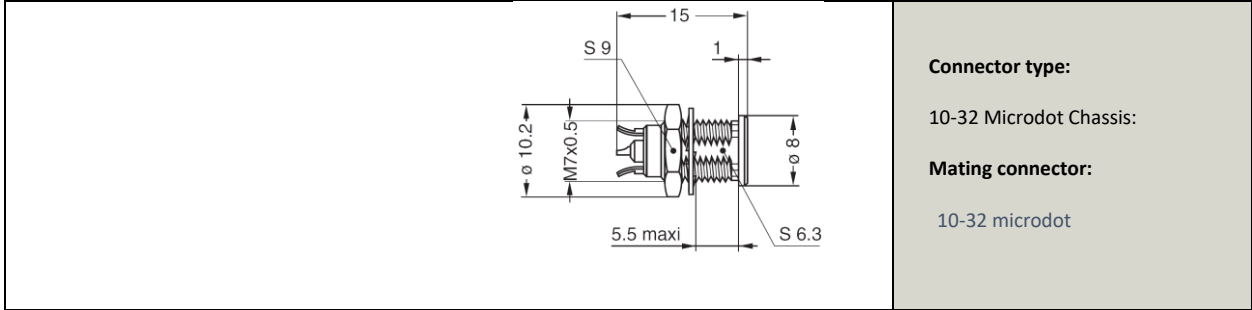

**Ordering information**

Support of Simcenter SCADAS Frames and Modules may be restricted in specific Simcenter Testlab application workbooks.

Please check with your local representative for full details.

SCM-VC8E-ER: The VC8E is eight-channel Input Module for Voltage, ICP®,

TEDS and Charge with extended charge input range  
SCL-VC8-ER: The VC8E is eight-channel Input Module for Voltage, ICP®, TEDS and Charge with extended charge input range

